

BRIDES

Pour le choix des brides de nombreuses possibilités tant au niveau dimensions, matériaux que de revêtements sont disponibles.

Il est également possible de prévoir deux brides différentes sur un manchon compensateur.

A la page suivante vous trouverez les différents types de bride.

Des brides spéciales sont disponibles sur demande.

FLANGE CHOICE

For the choice of flanges a great variety of combinations concerning connection dimensions, materials and coatings is available.

Also two different flange types on one compensator are possible.

On the following pages the most common types and dimensions are listed.

Special types are available upon request.

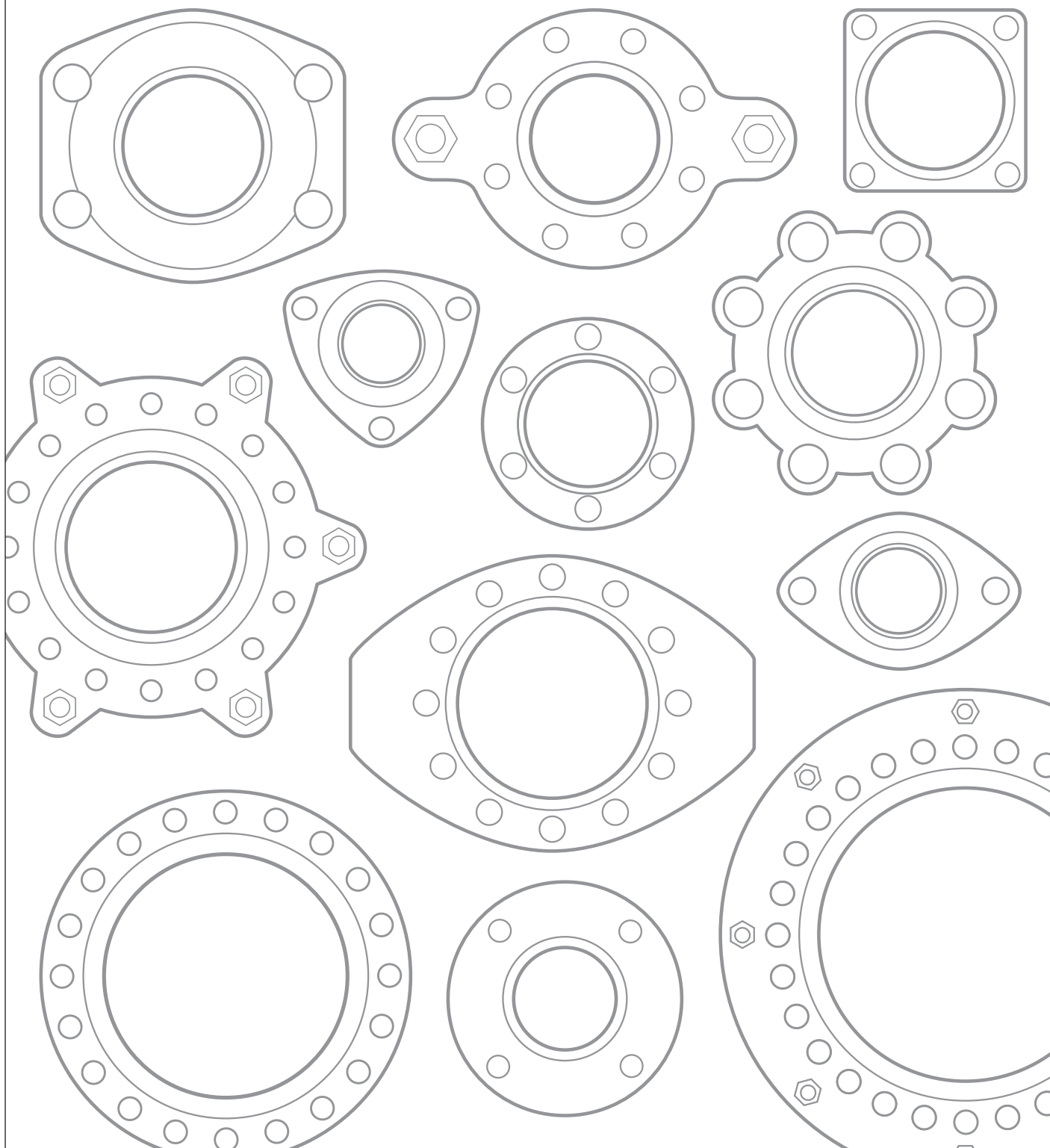

La nouvelle configuration de produit des compensateurs ERV:
<http://ervkonfigurator.elaflex.de>

The new product configurator for ERV Rubber Expansion Joints:
<http://ervconfigurator.elaflex.de>

Brides pour manchons compensateurs

FLANGES FOR RUBBER EXPANSION JOINTS

461

Dimensions des brides les plus courantes · *Commonly used Flange Measurements*

Standard de bride <i>Flange Standard</i>		DIN PN 6				DIN PN 10				DIN PN 16				DIN PN 25				DIN PN 40			
Référence <i>Part Number</i>		.6				.10				.16				.25				.40			
DN		D	k	n	l	D	k	n	l	D	k	n	l	D	k	n	l	D	k	n	l
mm	in.	mm	mm		mm	mm	mm		mm	mm	mm		mm	mm	mm		mm	mm	mm		mm
25	1"									115	85	4	14					115	85	4	14
32	1 ¼"	120	90	4	14					140	100	4	18					140	100	4	18
40	1 ½"	130	100	4	14					150	110	4	18					150	110	4	18
50	2"	140	110	4	14					165	125	4	18					165	125	4	18
65	2 ½"	160	130	4	14					185	145	4	18					185	145	8	18
80	3"	190	150	4	18					200	160	8	18					200	160	8	18
100	4"	210	170	4	18					220	180	8	18					235	190	8	22
125	5"	240	200	8	18					250	210	8	18					270	220	8	26
150	6"	265	225	8	18					285	240	8	22					300	250	8	26
200	8"	320	280	8	18	340	295	8	22	340	295	12	22	360	310	12	26	375	320	12	30
250	10"	375	335	12	18	395	350	12	22	405	355	12	26	425	370	12	30	450	385	12	33
300	12"	440	395	12	22	445	400	12	22	460	410	12	26	485	430	16	30	515	450	16	33
350	14"	490	445	12	22	505	460	16	22	520	470	16	26	555	490	16	33	580	510	16	36
400	16"	540	495	16	22	565	515	16	26	580	525	16	30	620	550	16	36	660	585	16	39
450	18"	595	550	16	22	615	565	20	26	640	585	20	30	670	600	20	36	685	610	20	39
500	20"	645	600	20	22	670	620	20	26	715	650	20	33	730	660	20	36	755	670	20	42
600	24"	755	705	20	26	780	725	20	30	840	770	20	36	845	770	20	39				
700	28"	860	810	24	26	895	840	24	30	910	840	24	36	960	875	24	42				
800	32"	975	920	24	30	1015	950	24	33	1025	950	24	39	1085	990	24	48				
900	36"	1075	1020	24	30	1115	1050	28	33	1125	1050	28	39	1185	1090	28	48				
1000	40"	1175	1120	28	30	1230	1160	28	36	1255	1170	28	42	1320	1210	28	56				

Matériaux : acier zingué (standard), acier inoxydable, laiton, aluminium, acier galvanisé à chaud, acier rilsanisé, etc. – voir page 403
 Materials: zinc plated steel (standard), stainless steel, bronze, aluminium, hot galvanized steel, RILSAN coated steel etc. – see page 403

Standard de bride <i>Flange Standard</i>		ANSI B 16.5 150 lb/sq. in						ANSI B 16.5 300 lb/sq. in.						SAE J518 c							
Référence <i>Part Number</i>		.ASA 150						.ASA 300						.SAE							
DN		D		k		n	l		D		k		n	l		G	H	I	L	n	l
mm	in.	mm	in.	mm	in.		mm	in.	mm	in.	mm	in.		mm	in.	mm	mm	mm	mm	mm	mm
25	1"	108,0	4 ½"	79,4	3 ½"	4	15,9	5/8"	123,8	4 7/8"	88,9	3 ½"	4	19,0	¾"						
32	1 ¼"	117,5	4 5/8"	88,9	3 ½"	4	15,9	5/8"	133,4	5 ¼"	98,4	3 7/8"	4	19,0	¾"	80	58,7	30,2	75	4	13
40	1 ½"	127,0	5"	98,4	3 7/8"	4	15,9	5/8"	155,6	6 1/8"	114,3	4 3/4"	4	22,2	¾"	95	70,0	35,7	83	4	13
50	2"	152,4	6"	120,7	4 ¾"	4	19,0	¾"	165,1	6 ½"	127,0	5"	8	19,0	¾"	102	78,0	43,0	95	4	13
65	2 ½"	177,8	7"	139,7	5 ½"	4	19,0	¾"	190,5	7 ½"	149,2	5 7/8"	8	22,2	7/8"	114	89,0	51,0	115	4	13
80	3"	190,5	7 ½"	152,4	6"	4	19,0	¾"	209,6	8 ¼"	168,3	6 5/8"	8	22,2	7/8"	134	106,4	62,0	125	4	18
100	4"	228,6	9"	190,5	7 ½"	8	19,0	¾"	254,0	10"	200,0	7 7/8"	8	22,2	7/8"	162	130,0	78,0	147	4	18
125	5"	254,0	10"	215,9	8 ½"	8	22,2	7/8"	279,4	11"	235,0	9 ¼"	8	22,2	7/8"	190	152,4	92,1	170	4	18
150	6"	279,4	11"	241,3	9 ½"	8	22,2	7/8"	317,5	12 ½"	269,9	10 5/8"	12	22,2	7/8"						
200	8"	342,9	13 ½"	298,5	11 ¾"	8	22,2	7/8"	381,0	15"	330,2	13"	12	25,4	1"						
250	10"	406,4	16"	361,9	14 ¼"	12	25,4	1"	444,5	17 ½"	387,3	15 ¼"	16	28,6	1 1/8"						
300	12"	482,6	19"	431,8	17"	12	25,4	1"	520,7	20 ½"	450,8	17 ¾"	16	31,7	1 ¼"						
350	14"	533,4	21"	476,2	18 ¾"	12	28,6	1 1/8"	584,2	23"	514,3	20 ¼"	20	31,7	1 ¼"						
400	16"	596,9	23 ½"	539,7	21 ¼"	16	28,6	1 1/8"	647,7	25 ½"	571,5	22 ½"	20	34,9	1 3/8"						
450	18"	635,0	25"	577,9	22 ¾"	16	31,7	1 ¼"	711,2	28"	628,7	24 ¾"	24	34,9	1 3/8"						
500	20"	698,5	27 ½"	635,0	25"	20	31,7	1 ¼"	774,7	30 ½"	685,8	27"	24	34,9	1 3/8"						
600	24"	812,8	32"	749,3	29 ½"	20	34,9	1 3/8"	914,4	36"	812,8	32"	24	41,3	1 5/8"						

Matériaux : acier zingué (standard), acier inoxydable, laiton, aluminium, acier galvanisé à chaud, acier rilsanisé, etc. – voir page 403
 Materials: zinc plated steel (standard), stainless steel, bronze, aluminium, hot galvanized steel, RILSAN coated steel etc. – see page 403

Standard de bride Flange Standard		BS 10 table D						BS 10 table E						BS 10 table F								
Référence Part Number		.BS 10D						.BS 10E						.BS 10F								
DN		D		k		n	l		D		k		n	l		D		k		n	l	
mm	in.	mm	in.	mm	in.		mm	in.	mm	in.	mm	in.		mm	in.	mm	in.	mm	in.		mm	in.
25	1"	114,3	4 1/2"	82,5	3 3/8"	4	14,3	9/16"	114,3	4 1/2"	82,5	3 3/8"	4	14,3	9/16"	120,6	4 3/4"	87,3	3 7/16"	4	17,5	11/16"
32	1 1/4"	120,6	4 3/4"	87,3	3 7/16"	4	14,3	9/16"	120,6	4 3/4"	87,3	3 7/16"	4	14,3	9/16"	133,3	5 1/4"	98,4	3 7/8"	4	17,5	11/16"
40	1 1/2"	133,3	5 1/4"	98,4	3 7/8"	4	14,3	9/16"	133,3	5 1/4"	98,4	3 7/8"	4	14,3	9/16"	139,7	5 1/2"	104,8	4 1/8"	4	17,5	11/16"
50	2"	152,4	6"	114,3	4 1/2"	4	17,5	11/16"	152,4	6"	114,3	4 1/2"	4	17,5	11/16"	165,1	6 1/2"	127,0	5"	4	17,5	11/16"
65	2 1/2"	165,1	6 1/2"	127,0	5"	4	17,5	11/16"	165,1	6 1/2"	127,0	5"	4	17,5	11/16"	184,1	7 1/4"	146,0	5 3/4"	8	17,5	11/16"
80	3"	184,1	7 1/4"	146,0	5 3/4"	4	17,5	11/16"	184,1	7 1/4"	146,0	5 3/4"	4	17,5	11/16"	203,2	8"	165,1	6 1/2"	8	17,5	11/16"
100	4"	215,9	8 1/2"	177,8	7"	4	17,5	11/16"	215,9	8 1/2"	177,8	7"	8	17,5	11/16"	228,6	9"	190,5	7 1/2"	8	17,5	11/16"
125	5"	254,0	10"	209,5	8 1/4"	8	17,5	11/16"	254,0	10"	209,5	8 1/4"	8	17,5	11/16"	279,4	11"	234,9	9 1/4"	8	22,2	7/8"
150	6"	279,4	11"	234,9	9 1/4"	8	17,5	11/16"	279,4	11"	234,9	9 1/4"	8	22,2	7/8"	304,8	12"	260,3	10 1/4"	12	22,2	7/8"
200	8"	336,5	13 1/4"	292,1	11 1/2"	8	17,5	11/16"	336,5	13 1/4"	292,1	11 1/2"	8	22,2	7/8"	368,3	14 1/2"	323,9	12 3/4"	12	22,2	7/8"
250	10"	406,4	16"	355,6	14"	8	22,2	7/8"	406,4	16"	355,6	14"	12	22,2	7/8"	431,8	17"	381,0	15"	12	25,4	1"
300	12"	457,2	18"	406,4	16"	12	22,2	7/8"	457,2	18"	406,4	16"	12	25,4	1"	489,0	19 1/4"	438,1	17 1/4"	16	25,4	1"

Matériaux : acier zingué (standard), acier inoxydable, laiton, aluminium, acier galvanisé à chaud, acier rilsanisé, etc. – voir page 403
 Materials: zinc plated steel (standard), stainless steel, bronze, aluminium, hot galvanized steel, RILSAN coated steel etc. – see page 403

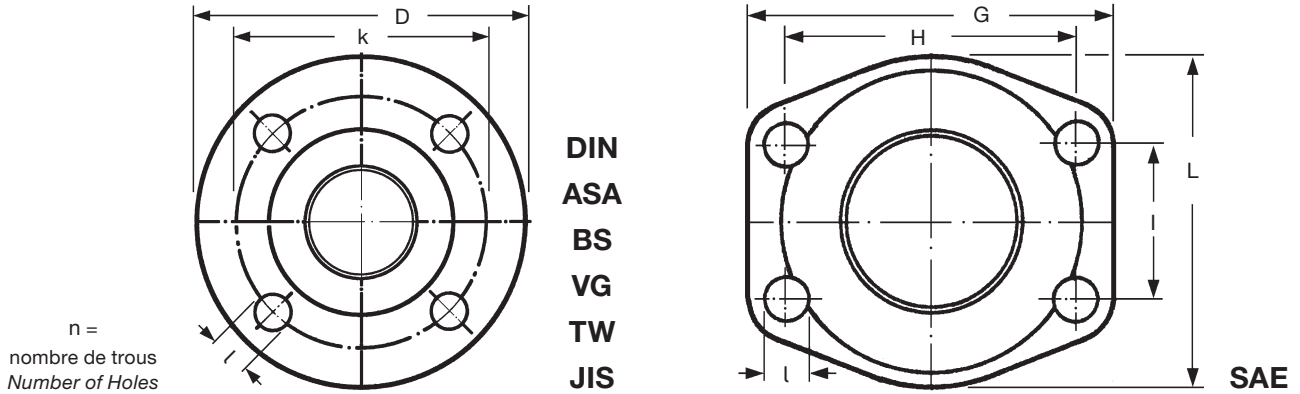

Standard de bride Flange Standard		VG 95959-1				DIN 28460 'TW'				JIS 5K				JIS 10K				JIS 16K			
Référence Part Number		.VG 95959-1				.TW				.JIS 5K				.JIS 10K				.JIS 16K			
DN		D	k	n	l	D	k	n	l	D	k	n	l	D	k	n	l	D	k	n	l
mm	in.	mm	mm		mm	mm	mm		mm	mm	mm		mm	mm	mm		mm	mm	mm		mm
25	1"													125	90	4	19	125	90	4	19
32	1 1/4"	100	76	6	11					115	90	4	15	135	100	4	19	135	100	4	19
40	1 1/2"	108	84	6	11					120	95	4	15	140	105	4	19	140	105	4	19
50	2"	120	96	6	11	154	130	8	11,5	130	105	4	15	155	120	4	19	155	120	8	19
65	2 1/2"	140	116	8	11	154	130	8	11,5	155	130	4	15	175	140	4	19	175	140	8	19
80	3"	150	126	8	11	154	130	8	11,5	180	145	4	19	185	150	8	19	200	160	8	23
100	4"	172	148	10	11	174	150	8	14,0	200	165	8	19	210	175	8	19	225	185	8	23
125	5"	200	176	10	11	204	176	8	14,0	235	200	8	19	250	210	8	23	270	225	8	25
150	6"	226	202	12	11	240	210	12	14,0	265	230	8	19	280	240	8	23	305	260	12	25
200	8"	288	264	16	11	308	274	16	16,0	320	280	8	23	330	290	12	23	350	305	12	25
250	10"									385	345	12	23	400	355	12	25	430	380	12	27
300	12"									430	390	12	23	445	400	16	25	480	430	16	27
350	14"									480	435	12	25	490	445	16	25	540	480	16	33
400	16"									540	495	16	25	560	510	16	27	605	540	16	33
450	18"									605	555	16	25	620	565	20	27	675	605	20	27
500	20"									655	605	20	25	675	620	20	27	730	660	20	33
600	24"									770	715	20	27	795	730	24	33	845	770	24	39

Matériaux : acier zingué (standard), acier inoxydable, laiton, aluminium, acier galvanisé à chaud, acier rilsanisé, etc. (pour 'TW' jusqu'à DN 150 standard = aluminium) – voir page 403
 Materials: zinc plated steel (standard), stainless steel, bronze, aluminium, hot galvanized steel, RILSAN coated steel etc. (by 'TW' up to DN 150 aluminium = standard) – see page 403

Tirants limiteurs – Type ZS

Le tableau montre que les réactions aux pressions jusqu'au diamètre 50 sont assez faibles, et que les limiteurs de course ne sont normalement pas nécessaires. Ils sont à prévoir quand il n'est pas possible de fixer la tuyauterie avec suffisamment de points fixes ou si un soulagement partiel des points fixes est désiré.

Les tirants limiteurs sont dimensionnés de telle manière qu'ils peuvent absorber les forces de réaction de la pression d'épreuve.

Les versions avec haubanage intégré donnent de très bons résultats pour la limitation axiale. Les tirants limiteurs (acier 8.8) sont ajustables à la longueur de montage souhaitée. Ils sont logés dans des amortisseurs en élastomère qui réduisent le bruit. A partir du diamètre 350, les tirants limiteurs sont logés par défaut dans des bagues coniques et des coupelles sphériques.

Forces de réaction pour manchons compensateurs ERV (longueur de montage = 130 mm)

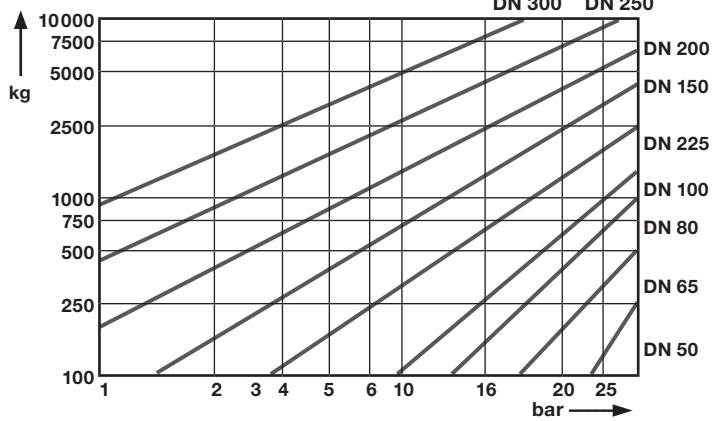

Pressure thrust forces of ERV Expansion Joints (installation length = 130 mm)

Diamètre nominal DN mm	Nombre de tirants Number tie rods	Référence Part Number Type
25	2	ERV 25 ... ZS
32	2	ERV 32 ... ZS
40	2	ERV 40 ... ZS
50	2	ERV 50 ... ZS
65	2	ERV 65 ... ZS
80	2	ERV 80 ... ZS
100	2	ERV 100 ... ZS
125	2	ERV 125 ... ZS
150	2	ERV 150 ... ZS
200	2	ERV 200 ... ZS
250	2	ERV 250 ... ZS
300	4	ERV 300 ... ZS
350	4	ERV 350 ... ZS
400	4	ERV 400 ... ZS
500	4	ERV 500 ... ZS
600	4	ERV 600 ... ZS

Valeurs pour brides DIN PN 10. Le nombre de tirants peut varier en fonction du standard de bride.

Values for flanges DIN PN 10, number of tie rods may change with different flange standards.

Tied Flanges – Type ZS

The table shows that the pressure thrust forces in small ERV dimensions up to DN 50 are this low that limiters normally are not necessary. Limiters are recommended when it is not possible to secure the pipe system with sufficient fixed points or when a part relief of the fixed points is desired.

The required limiters are measured to absorb also the reaction forces resulting from the test pressure.

For the mainly required axial limitation the shown types with integrated tie bars have proved well. The tie bars with high stability (steel 8.8) can be adjusted to the actual installation measurements. The tie bars lie elastically in noise reducing rubber bushes of weatherproof rubber. From DN 350 the tie rods lie in principal in conical seats and spherical washers.

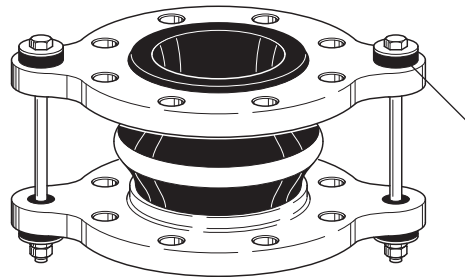

Tirants avec limitation extérieure et amortisseurs en caoutchouc
Type ... ZS
(jusqu'au/up to DN 300)
Tie rods with outer limitation in rubber bushings

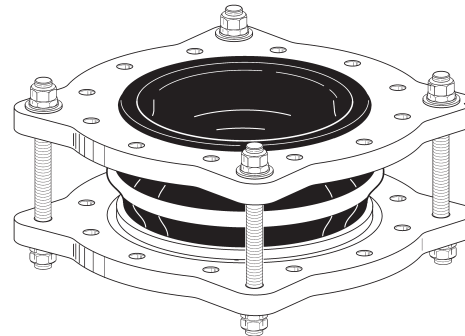

Tirants avec limitation extérieure avec coupelle sphérique et bague conique
Type ... ZS
(jusqu'au/from DN 350)
Tie rods with outer limitation in spherical discs and conical seats

Exécutions spéciales · Special Designs

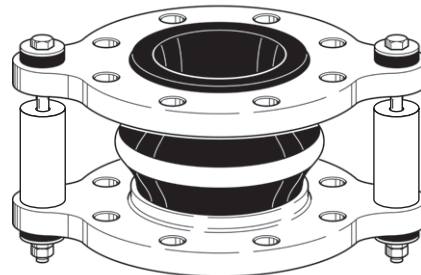

Tirants avec limitation intérieure et extérieure
Type ... ZSS
(bis/up to DN 300)
Tie rods with inner and outer limitation

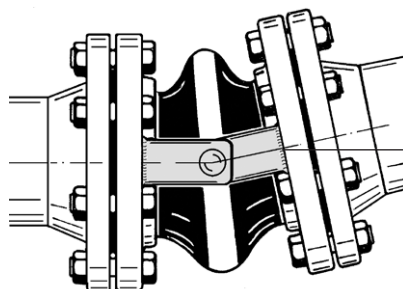

Limitation angulaire
Type ... RG
Angular limiter